

Do not connect pin 5 of serial cable to RXTX board to prevent ground loop

SoftRock Projects	
RXTX+Xtall v6.3	
Tony KB9YIG	Page 1 of 4
7/22/08	

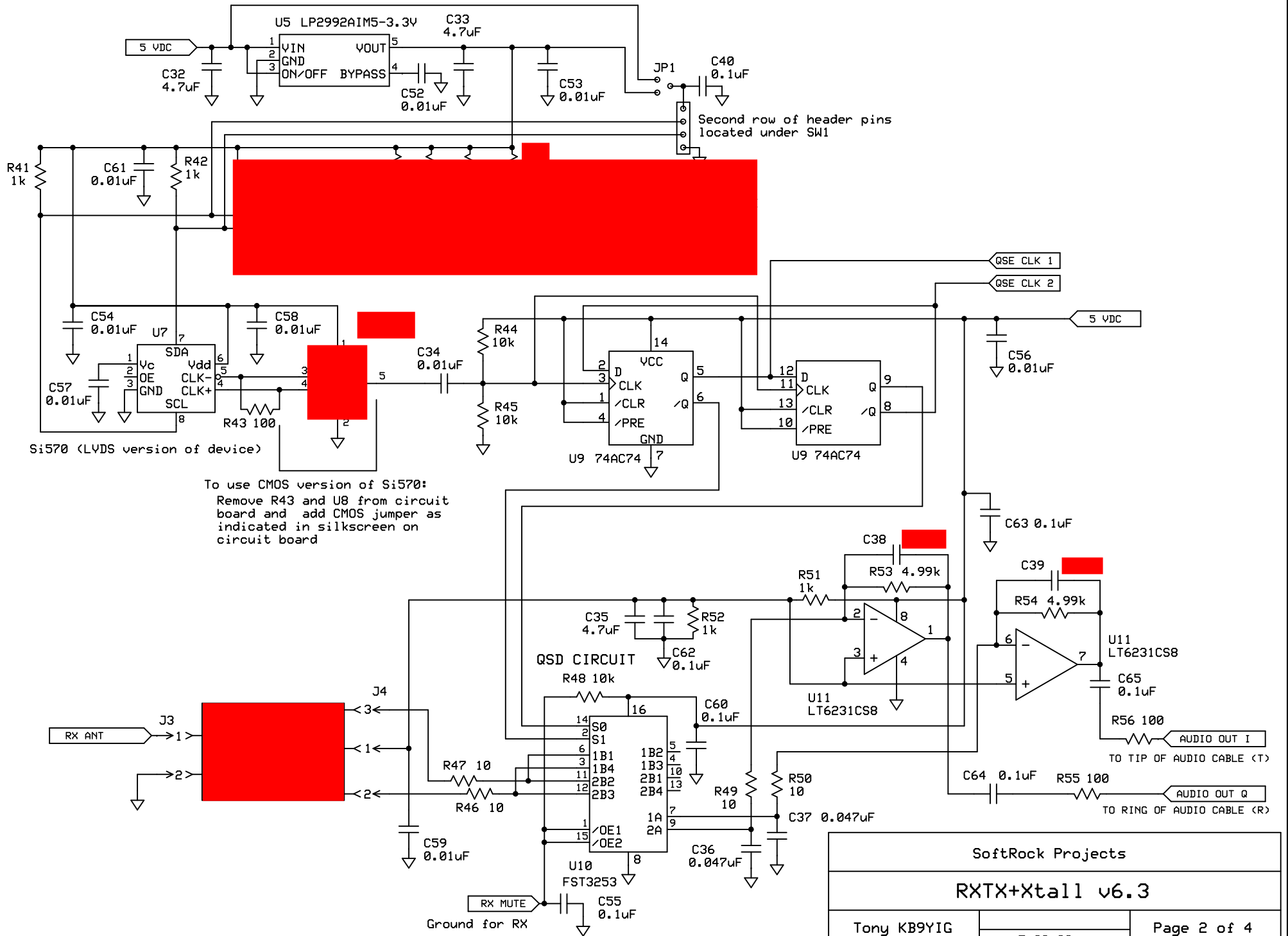

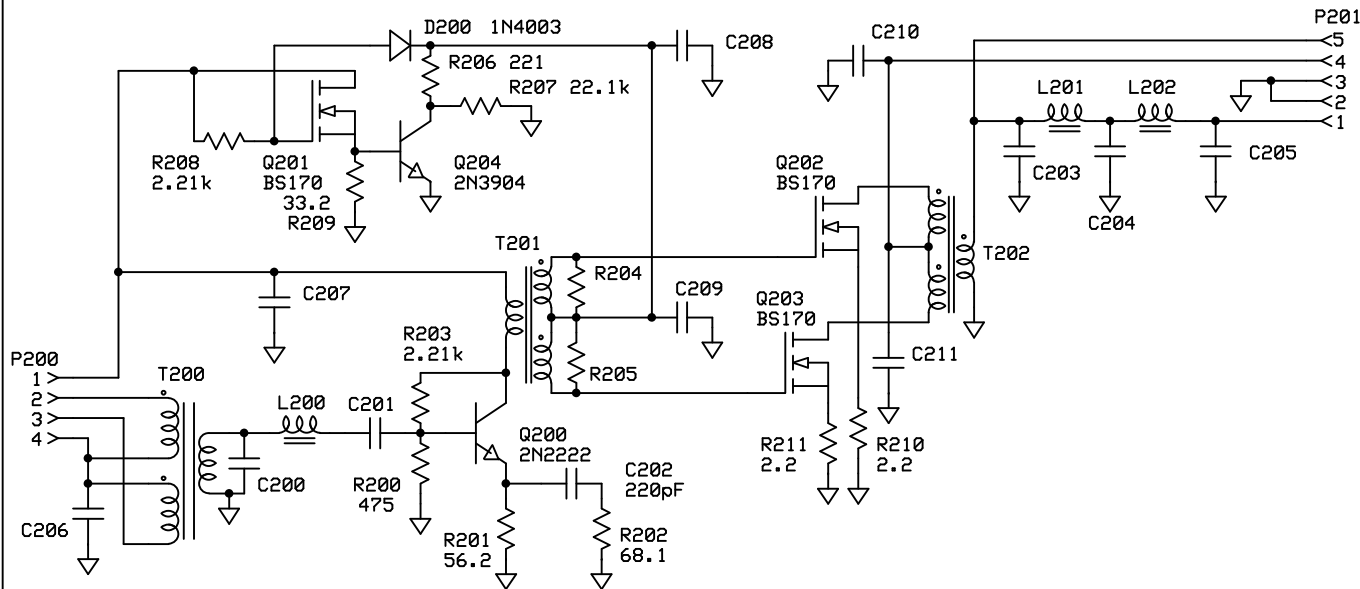

TX PA/Filter module

Bill of Materials for TX PA/Filter module

C, R, L, T as listed in tables below

Component	Used where	Quantity
220pF ceramic	C202	1
Resistors		
475 1%	R200	1
56.2 1%	R201	1
68.1 1%	R202	1
2.21k 1%	R203, R208	2
221 1%	R206	1
22.1k 1 1%	R207	1
33.2 1%	R209	1
2.2	R210, R211	2
Diodes		
Used where		Quantity
1N4003	D200	1
Transistors		
Used where		Quantity
2N2222A	Q200	1
BS170	Q201, Q202, Q203	3
2N3904	Q204	1
Connectors		
Used where		Quantity
4-pin header	P200	1
5-pin header	P201	1
Circuit board		
v6.3 PA/Filter board		1
Hardware		
Quantity		Quantity
6-32 1/2 inch machine screw		1
6-32 hex nut		1
#6 lock washer		1
T018 Heat Sink for Q200		1
T0220 Heat Sink for Q201, Q202, Q203		1
T0220 Sil-Pad		1
#4 nylon washer		1

Band specific values for TX PA/Filter module

Bands	T200	T201	T202	L200
160m	primaries 21T bifilar #30 (2x13 in.) secondary 7.1uH 42T #30 (24 in.) T37-2 (red) core	primary 6T of #30 (10 in.) secondaries 3T bifilar of #30 (2x5 in.) BN-43-2402 core	primaries 4T bifilar of #30 (2x6 in.) secondary 5T of #30 (9 in.) BN-43-2402 core	30uH 86T #30 (46 in.) T37-2(red) core
80m, 40m	primaries 17T bifilar #30 (2x10 in.) secondary 5.0uH 34T #30 (19 in.) T30-2 (red) core	primary 6T of #30 (10 in.) secondaries 3T bifilar of #30 (2x5 in.) BN-43-2402 core	primaries 4T bifilar of #30 (2x6 in.) secondary 5T of #30 (9 in.) BN-43-2402 core	4.7uH 33T #30 (17 in.) T30-2(red) core
30m, 20m, 17m	primaries 11T bifilar #30 (2x 8 in.) secondary 1.74H 22T #30 (14 in.) T30-6 (yellow) core	primary 6T of #30 (10 in.) secondaries 3T bifilar of #30 (2x5 in.) BN-61-2402 core	primaries 4T bifilar of #30 (2x6 in.) secondary 5T of #30 (9 in.) BN-61-2402 core	1.6uH 21T #30 (14 in.) T30-6 (yellow) core
15m, 12m, 10m	primaries 8T bifilar #30 (2x 6 in.) secondary 0.81uH 15T #30 (11 in.) T30-6 (yellow) core	primary 6T of #30 (10 in.) secondaries 3T bifilar of #30 (2x5 in.) BN-61-2402 core	primaries 4T bifilar of #30 (2x6 in.) secondary 5T of #30 (9 in.) BN-61-2402 core	2.1uH 24T #30 (15 in.) T30-6 (yellow) core

Bands	L201 and L202	C200	C201	C203, C205	C204	R202	C206 through C211	R204, R205
160m	3.4uH 29T #26 (17 in.) T37-2(red) core	1000pF	270pF	2200pF	4700pF	omit	0.1uF size 1206	221 1%
80m, 40m	1.4uH 19T #26 (13 in.) T37-2(red) core	220pF	220pF	470pF	820pF	omit	0.1uF size 1206	221 1%
30m, 20m, 17m	0.6uH 14T #26 (10 in.) T37-6 (yellow) core	82pF	82pF	150pF	330pF	omit	0.1uF size 1206	100
15m, 12m, 10m	0.36uH 11T #26 (9 in.) T37-6 (yellow) core	47pF	22pF	100pF	180pF	use	0.01uF size 1206	220 1%

SoftRock Projects	
RXTX+Xtall v6.3	
Tony KB9YIG	Page 3 of 4
7/22/08	